

## TONGUE AND GROOVE

You can easily manufacture T&G for boarding in flooring or panelling on your planer molder. The accuracy of your T&G will be in direct proportion to the accuracy of your setup. It is imperative that the work piece is held upright and on center in relationship to the cutter when being machined. This can be easily accomplished by building guides that have a raised insert directly under the cutter head. The advantage of the insert guides will become apparent the first time you use them.

Traditional guides that grip the stock tightly for the full length will quickly spread and jam when you feed through the first piece of lumber with a slight twist in it. The insert guide grips the lumber tightly directly under the cutting head for a distance of 4" only, allowing the stock to feed accurately and smoothly.

The insert can be made from kiln dried maple or other fine grained hardwoods or white poly (plastic). In the drawings we have used an insert which is 5/16" thick. The guide has been routed out to a depth of 1/4" to accommodate the inserts width and height. **IT IS EXTREMELY IMPORTANT TO CHAMFER THE LEADING EDGE OF THE INSERT** as shown. The insert now protrudes 1/16" from the guide. It is fastened to the guide with countersunk screws.

The guides should be approximately 42" long and support the stock to within 3/4" of the top edge. ( For a 4" wide board build the guide 3 1/4" high). The guides must be properly aligned in relationship to the head before fastening them to the bedboard.

Before starting production accurately pre-size your stock.

The custom knife holder can be used to accommodate both tongue and groove knives using the common gib provided. Position both knives in the holder, tighten the gib securely ( 5-7 ft. lbs.). The custom holder should now be positioned to centre the groove knife in relationship to the work piece. Run test pieces and when alignment is correct machine the groove in your entire run. Disconnect power and move the custom holder into the correct position to machine the tongue. **NOTE:** You will find it easier to move the custom holder than your guides. To double production and help prevent premature roller wear consider using a second custom knife holder and guide setup. This will enable you to run 2 pieces of groove or 2 pieces of tongue at the same time.

# TONGUE AND GROOVE

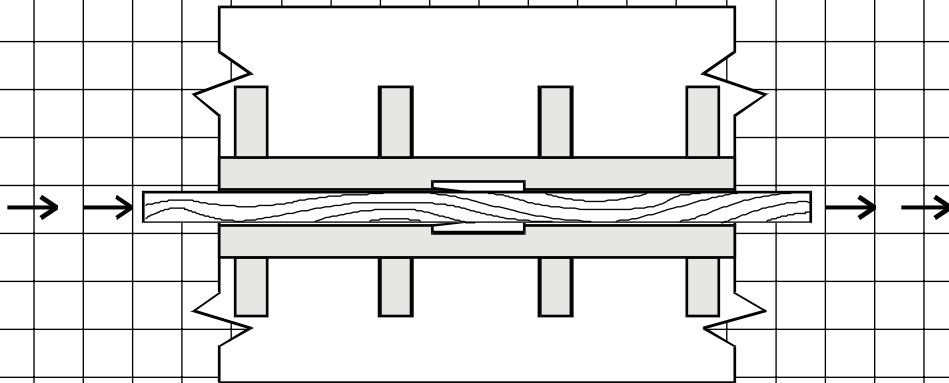

TOP VIEW

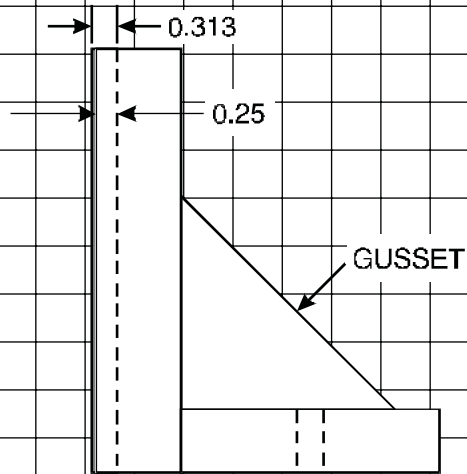

END VIEW

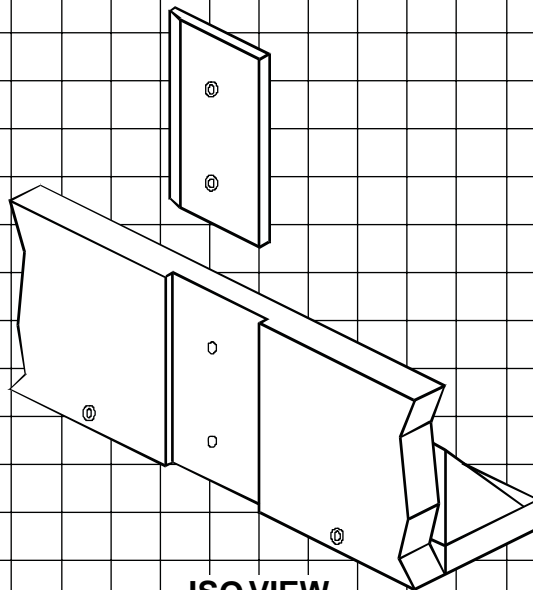

ISO VIEW

# TONGUE AND GROOVE

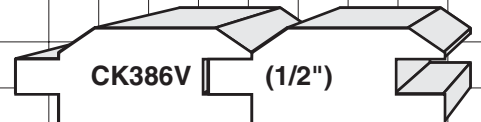
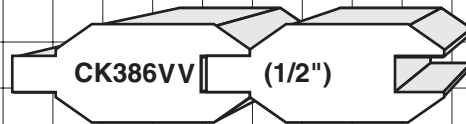
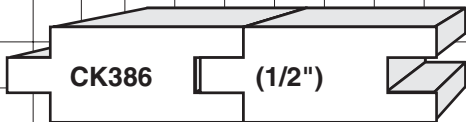
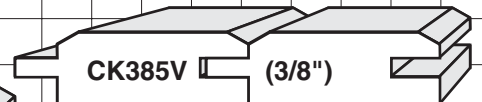
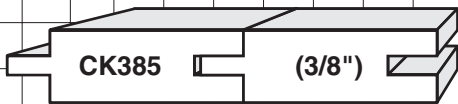
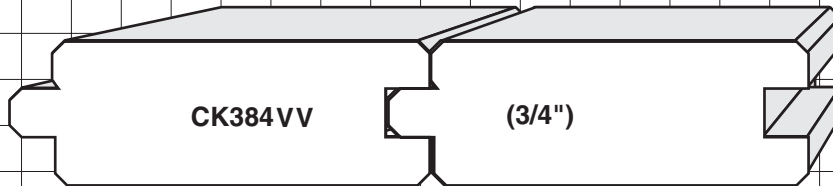
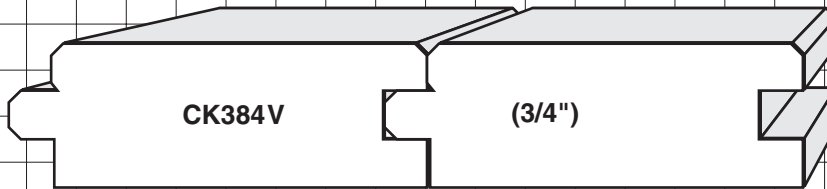
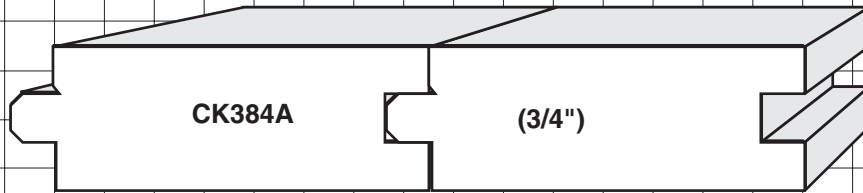

# TONGUE AND GROOVE

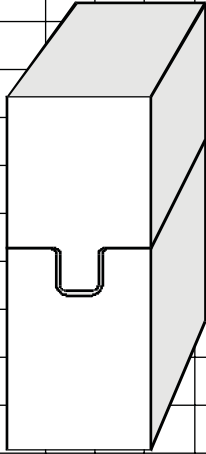

**CK388**  
1"

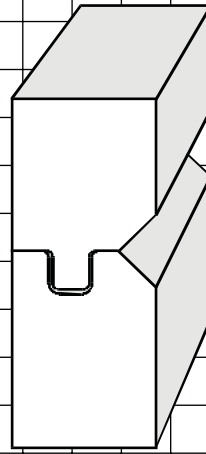

**CK388V**  
1"

Please note that the 1" tongue and groove knives are actually 3/4" and the 2" tongue and groove knives are actually 1-1/2".

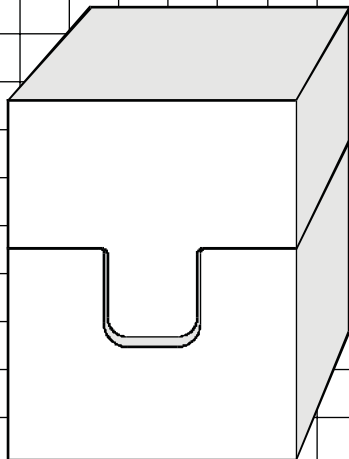

**CK389**  
2"

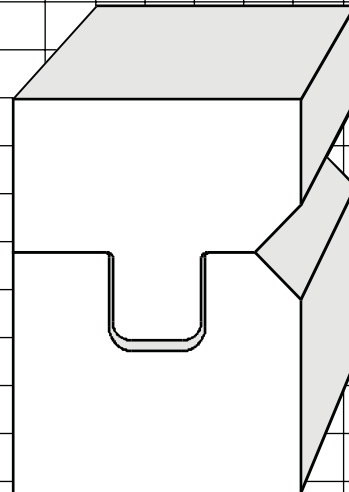

**CK389V**  
2"