

CROWN MOLDING

Crown Moldings require two separate passes to produce the finished pattern since the molding is cut on both top and bottom. Both the Top and Bottom profile knives use the same set of Steel Gibs and Counterbalances.

As illustrated in Fig. G, pass One is for the Bottom, and creates the bevelled sides which mount against the wall and ceiling. After all stock has been passed through the bottom knife, pass Two will create the Top; the decorative profile that remains exposed to the eye once the molding has been mounted.

FIGURE G

PASS TWO

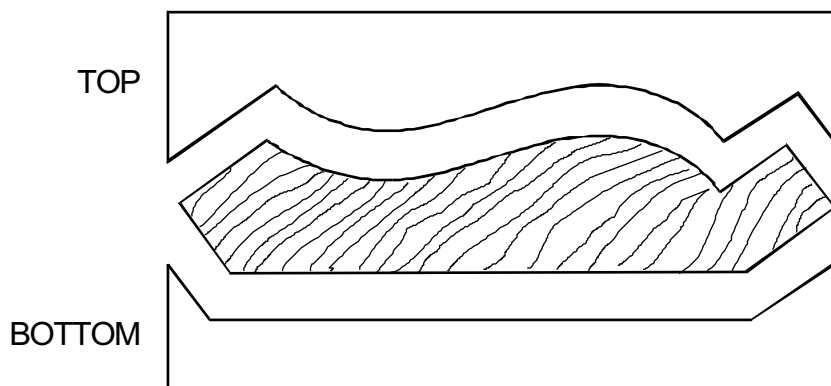

PASS ONE

**TO ORDER
CALL 1-800-821-6651**

CROWN MOULDINGS

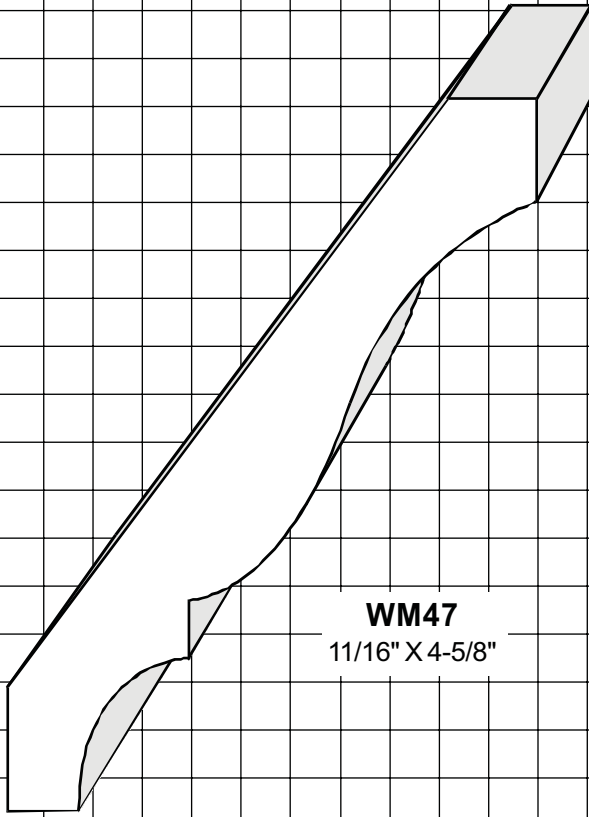

WM47
11/16" X 4-5/8"

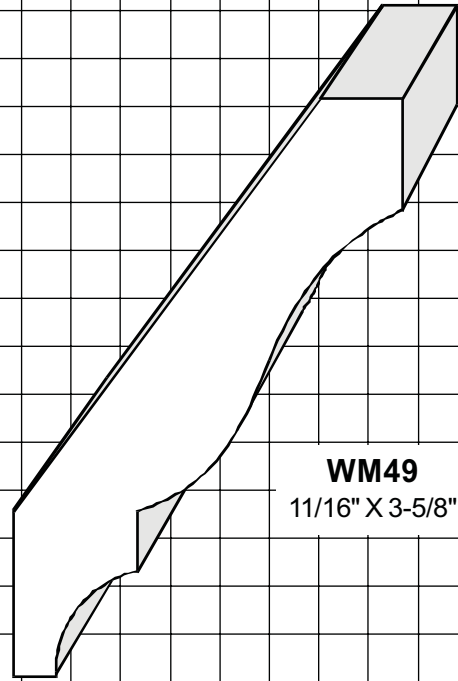

WM49
11/16" X 3-5/8"

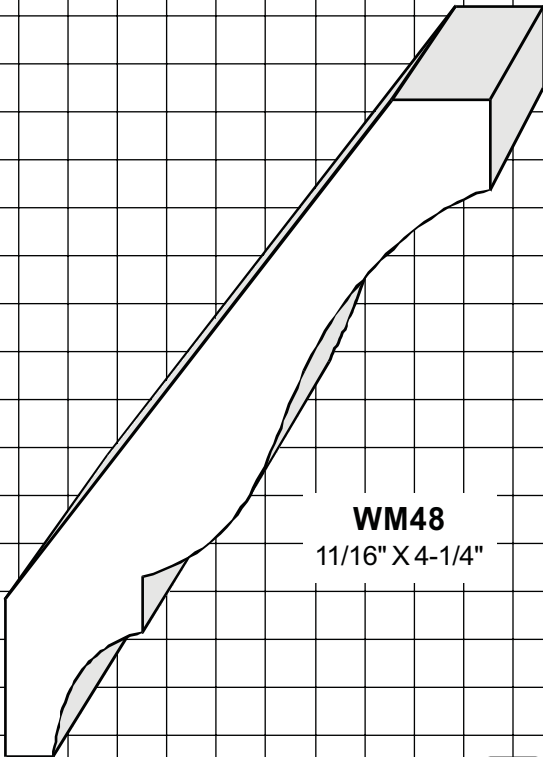

WM48
11/16" X 4-1/4"

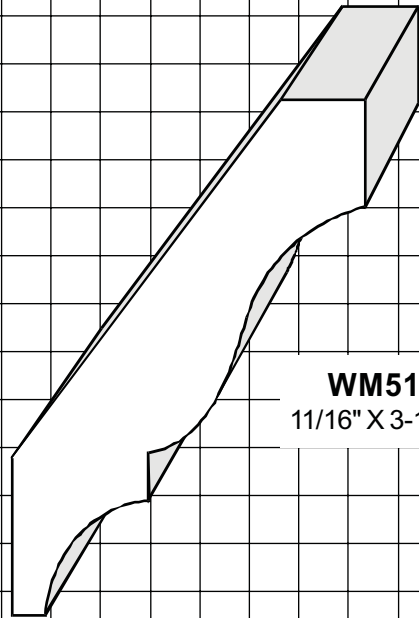

WM51
11/16" X 3-1/4"

CROWN MOULDINGS

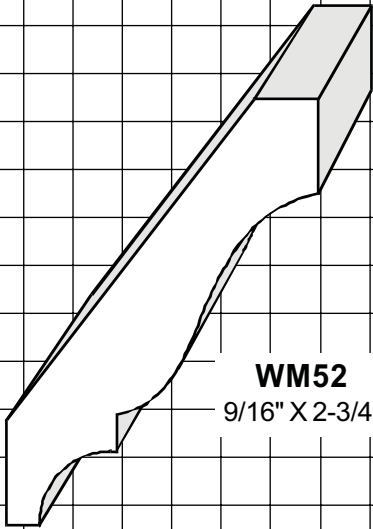

WM52
9/16" X 2-3/4"

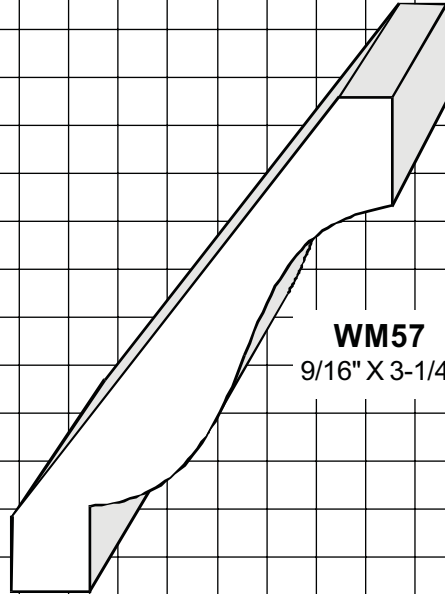

WM57
9/16" X 3-1/4"

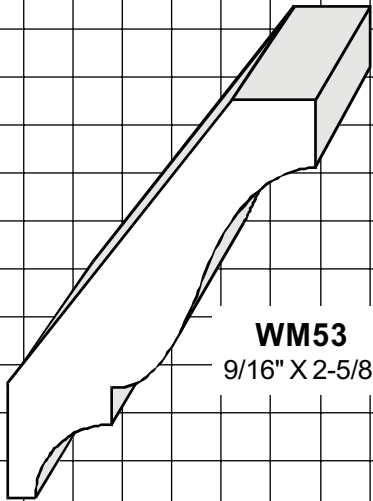

WM53
9/16" X 2-5/8"

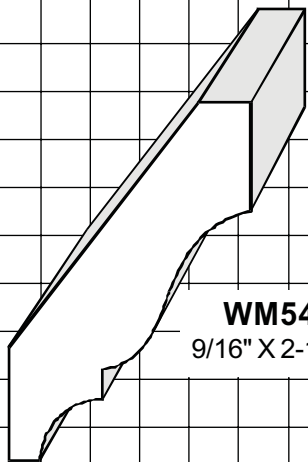

WM54
9/16" X 2-1/4"

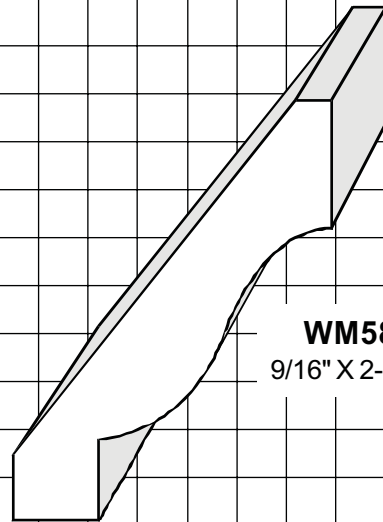

WM58
9/16" X 2-3/4"

CROWN MOULDINGS

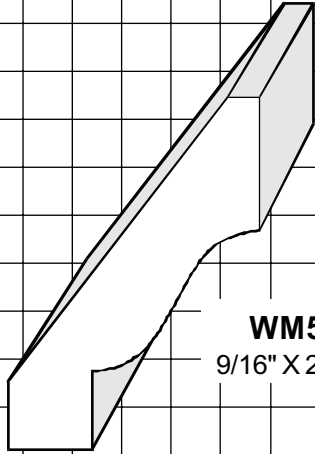

WM59
9/16" X 2-1/4"

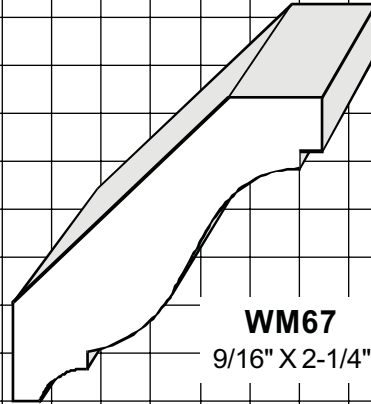

WM67
9/16" X 2-1/4"

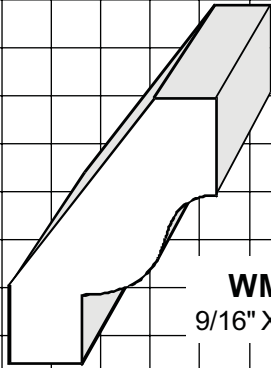

WM60
9/16" X 1-3/4"

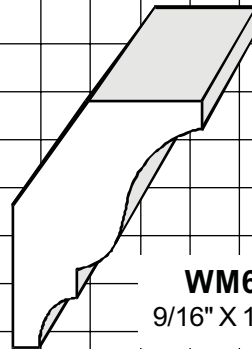

WM68
9/16" X 1-5/8"

CROWN MOULDINGS

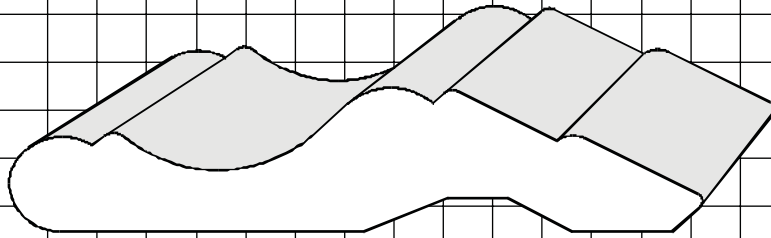

WM4100
3/4" X 3-5/8"

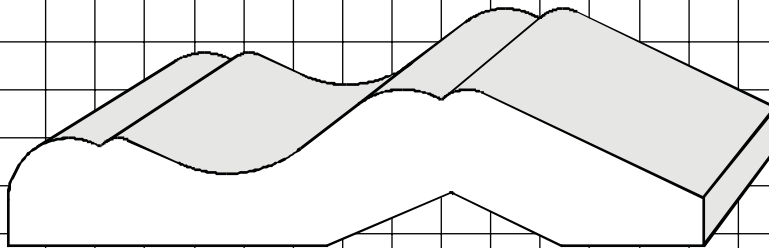

WM4101
3/4" X 3-5/8"

CROWNS

WM4020
(11/16" x 5")

WM4021
(11/16" x 5-1/4")

WM4022
(11/16" x 5-1/2")

WM4023
(11/16" x 5-3/4")

WM4024
(11/16" x 6")

CROWNS

WM4025
(3/4" x 5")

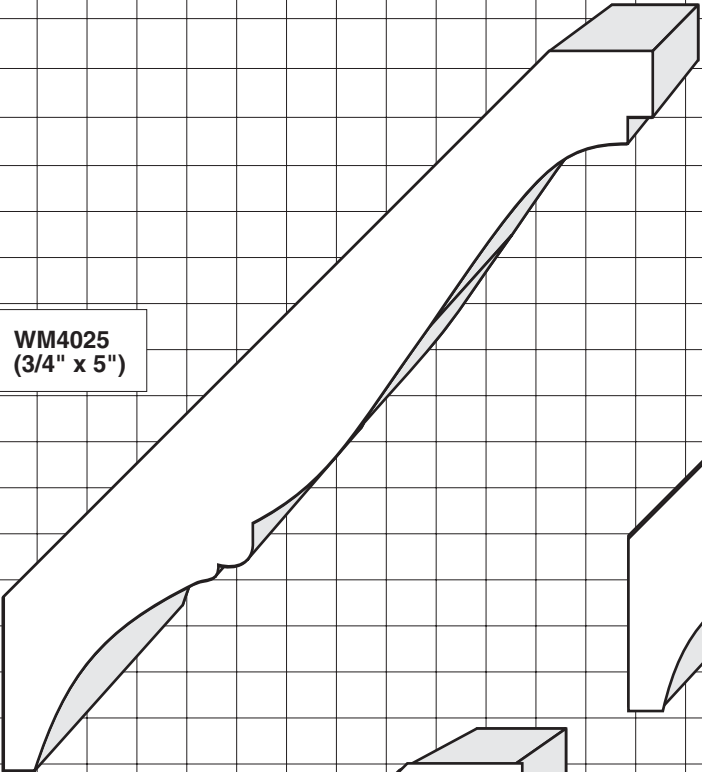

WM4026
(3/4" x 4-1/2")

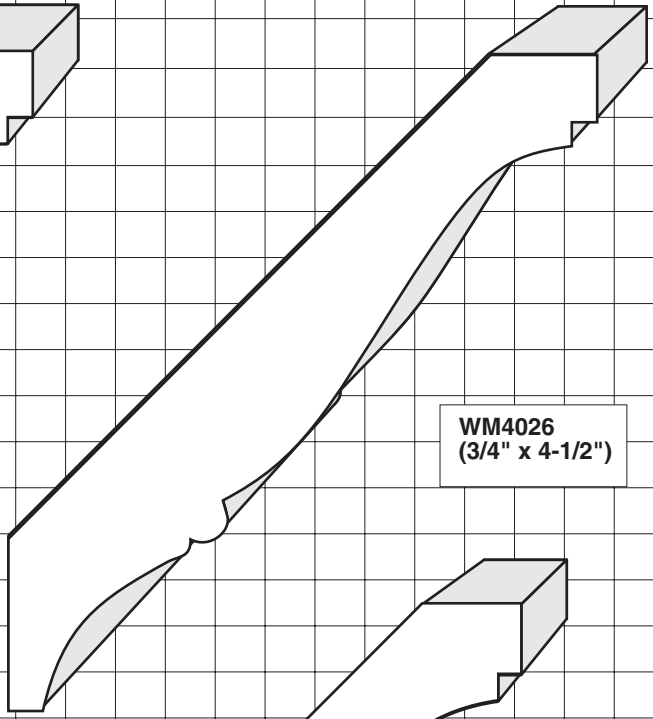

WM4027
(3/4" x 4")

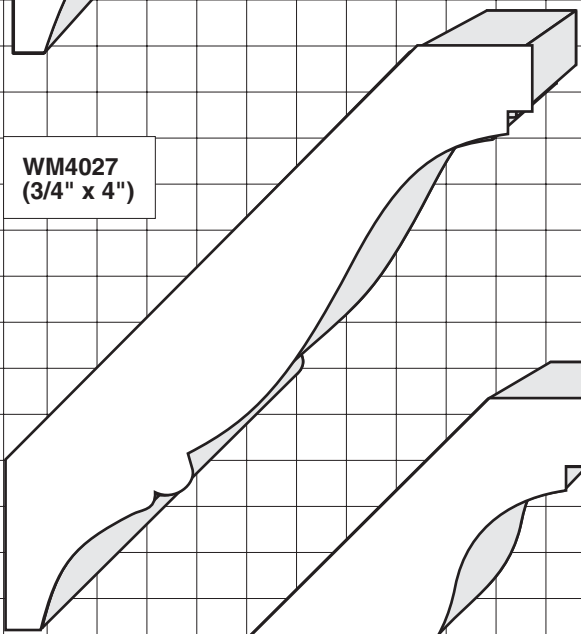

WM4028
(3/4" x 3-1/2")

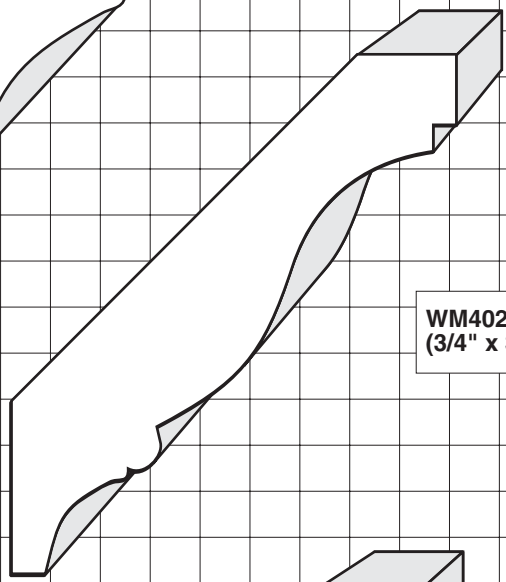

WM4029
(3/4" x 3")

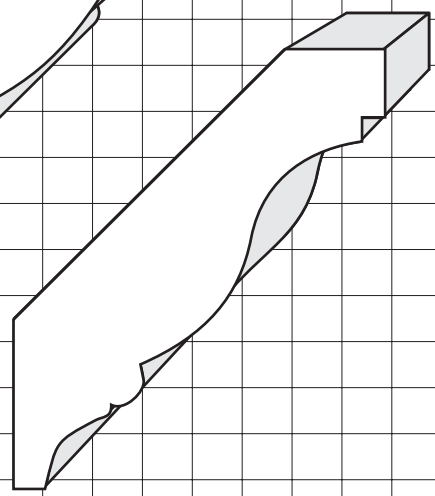

WM4030
(3/4" x 2-1/2")

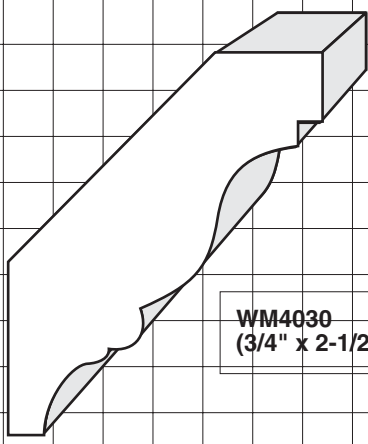

CROWNS

WM4031
(3/4" x 5")

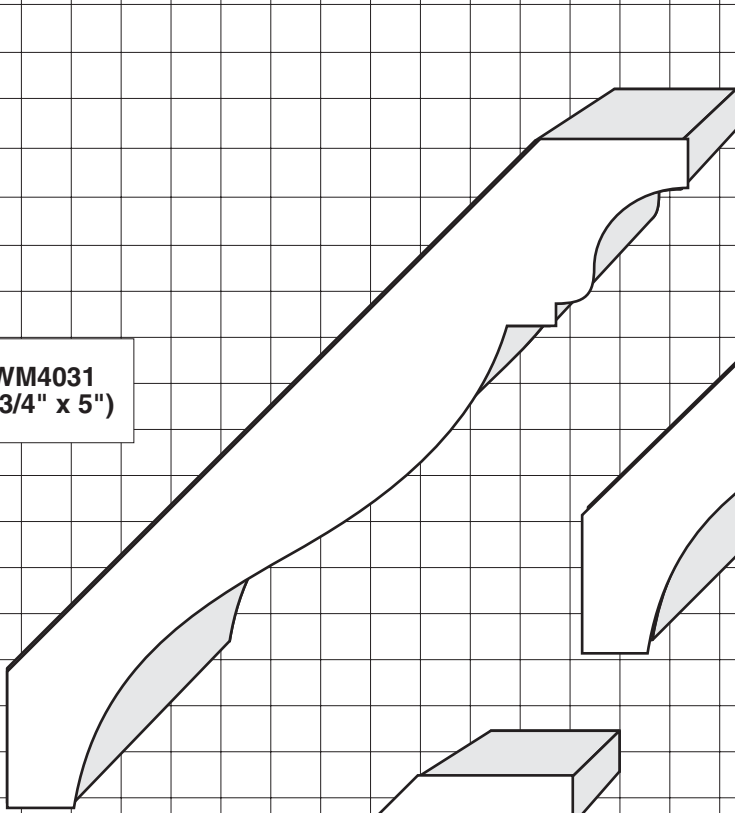

WM4032
(3/4" x 4-1/2")

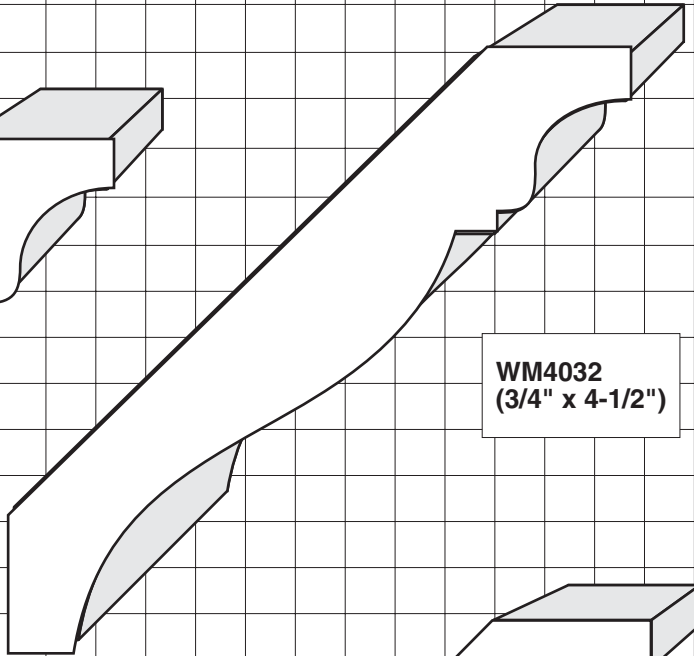

WM4033
(3/4" x 4")

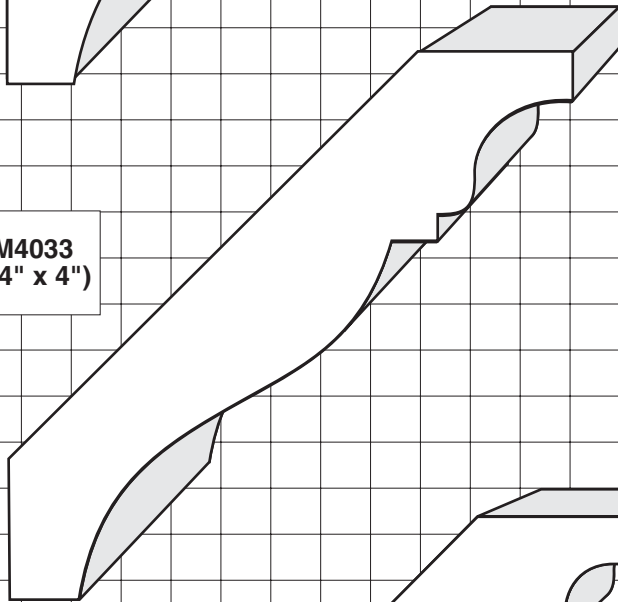

WM4034
(3/4" x 3-1/2")

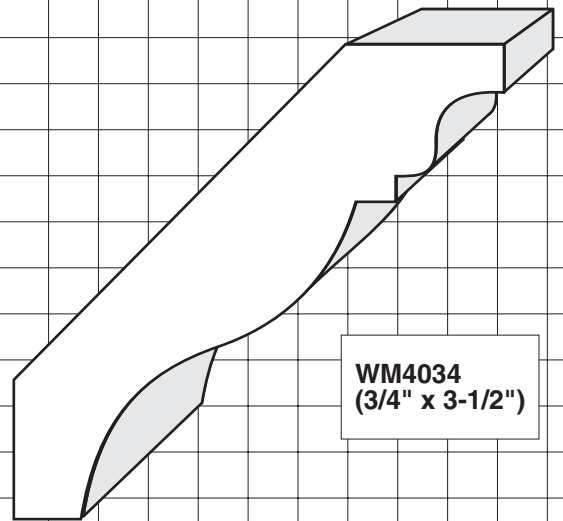

WM4035
(3/4" x 3")

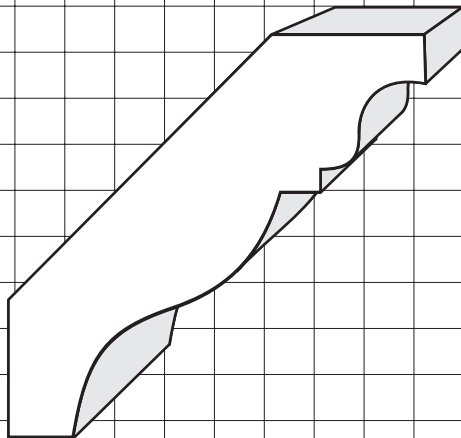

WM4036
(3/4" x 2-1/2")

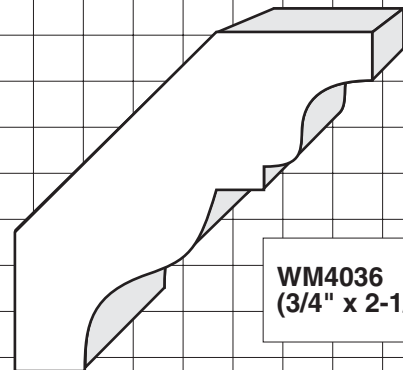

CROWNS

WM4037
(3/4" x 4-1/2")

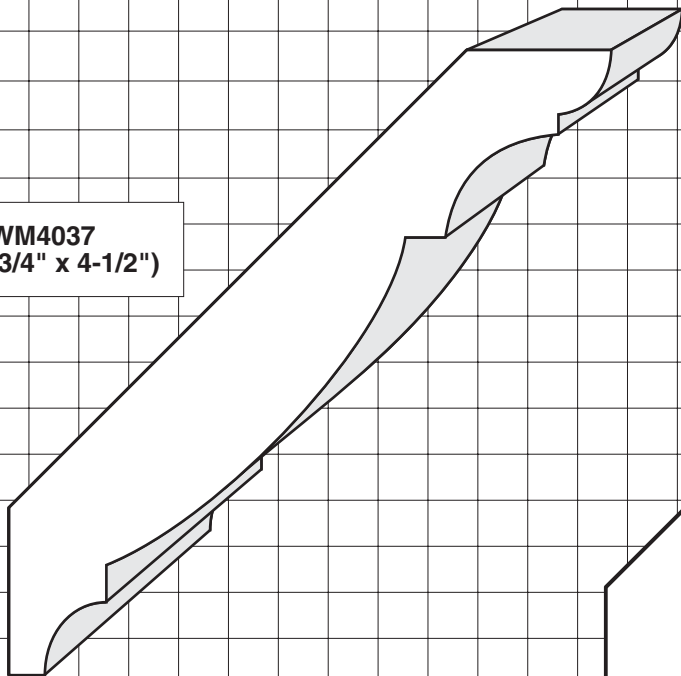

WM4038
(3/4" x 4")

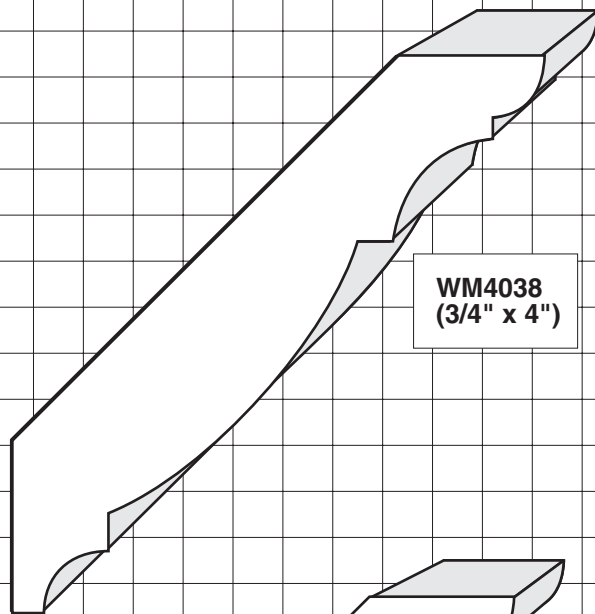

WM4039
(3/4" x 3-1/2")

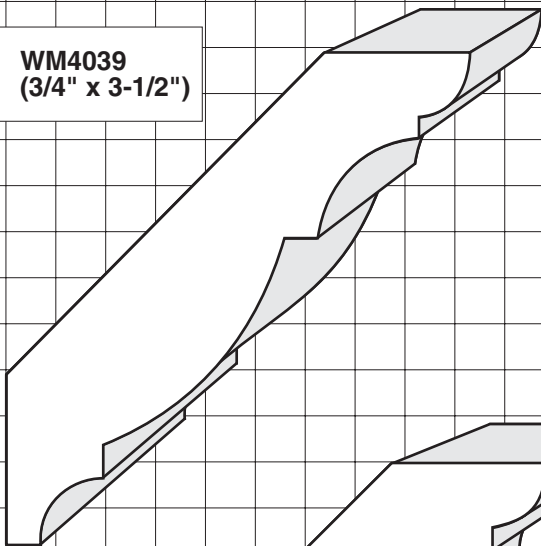

WM4040
(3/4" x 3")

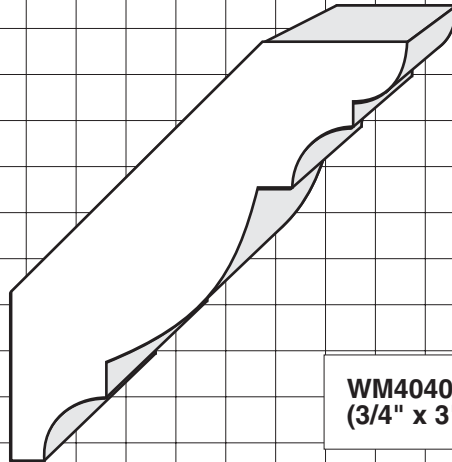

WM4041
(3/4" x 2-1/2")

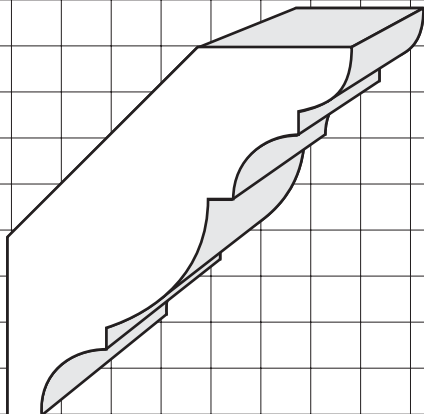

CROWNS

WM4042
(3/4" x 5")

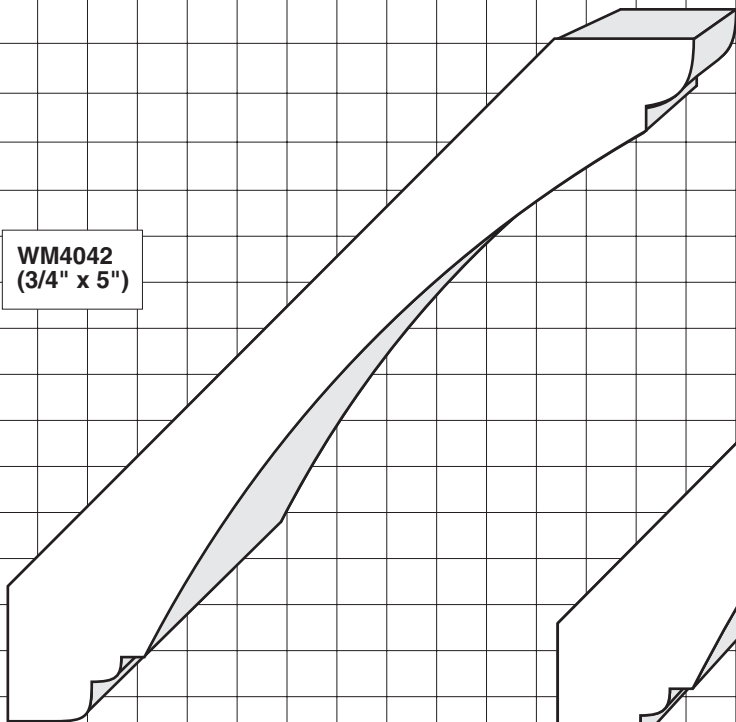

WM4043
(3/4" x 4-1/2")

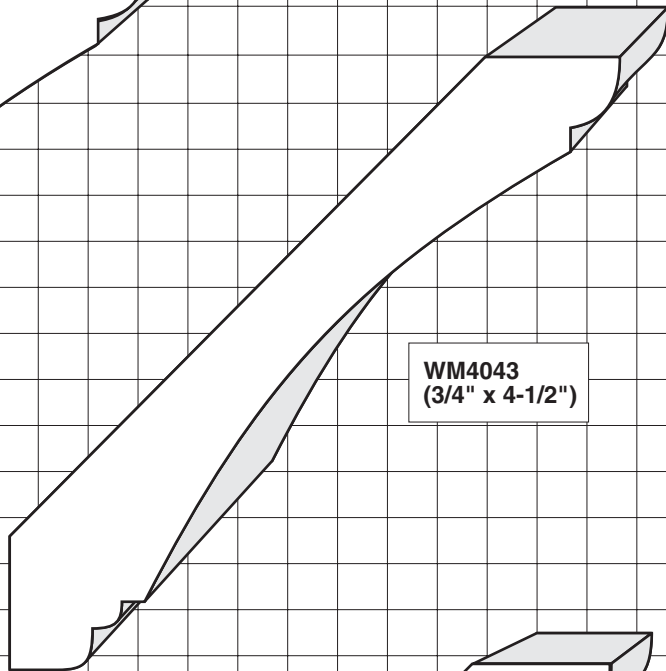

WM4044
(3/4" x 4")

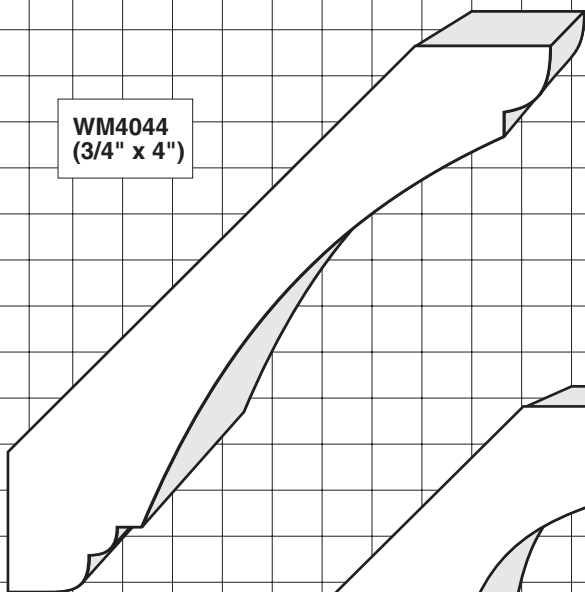

WM4045
(3/4" x 3-1/2")

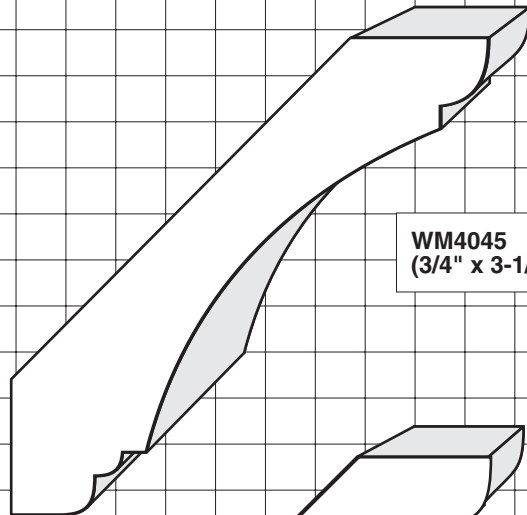

WM4047
(3/4" x 2-1/2")

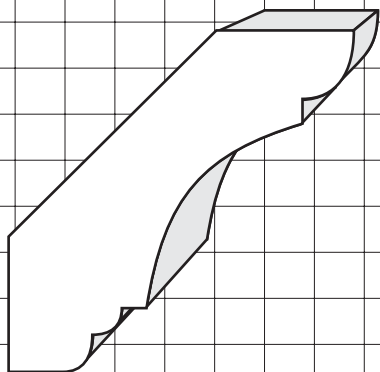

WM4046
(3/4" x 3")

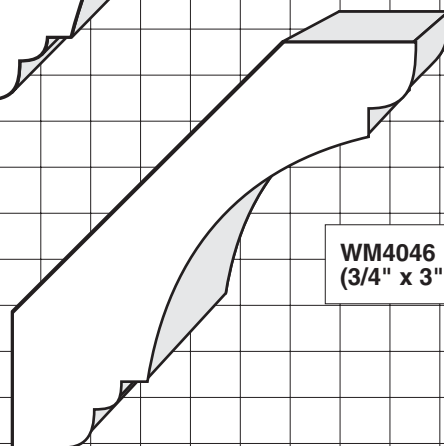

CROWNS

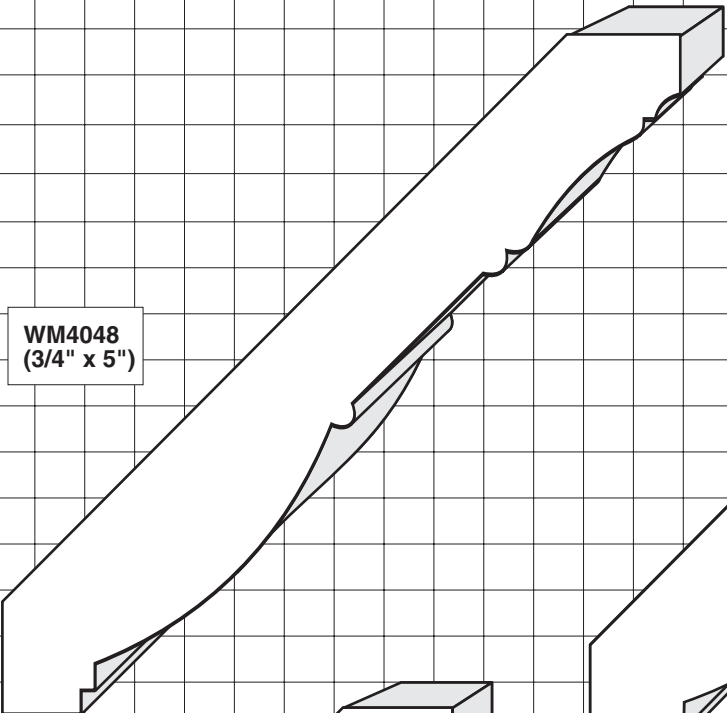

WM4048
(3/4" x 5")

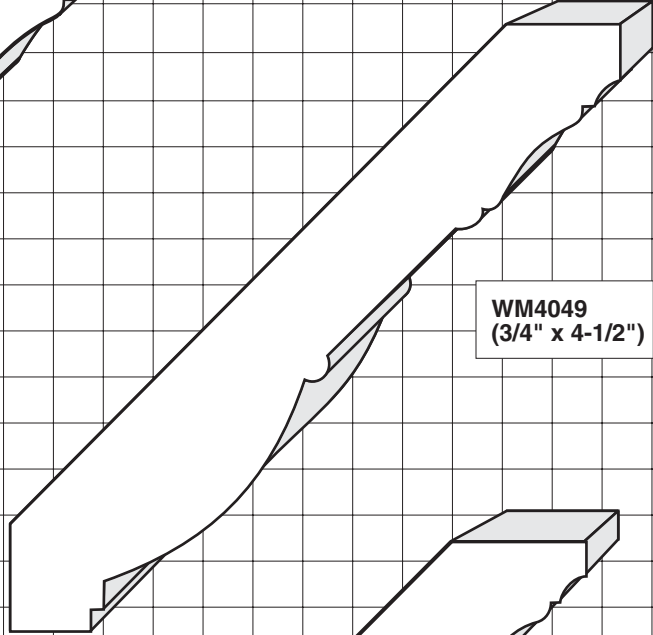

WM4049
(3/4" x 4-1/2")

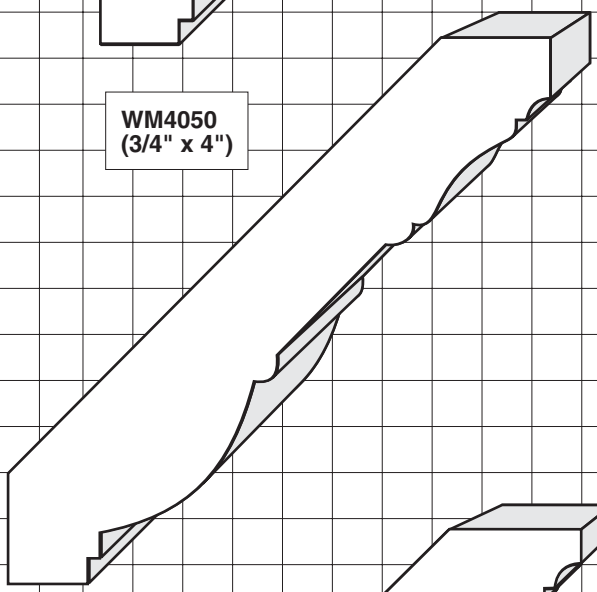

WM4050
(3/4" x 4")

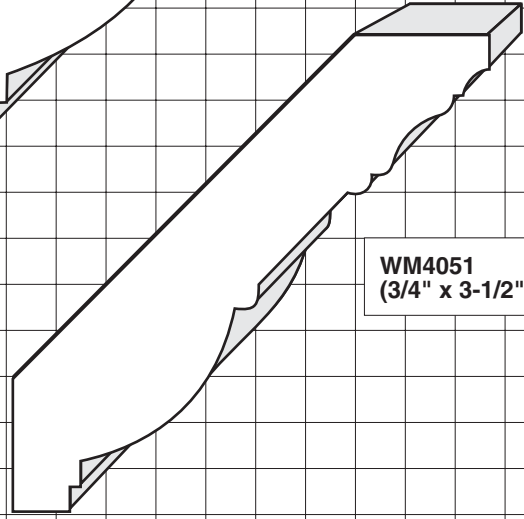

WM4051
(3/4" x 3-1/2")

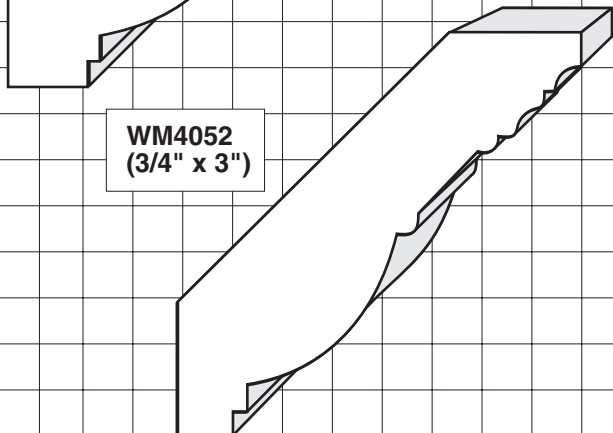

WM4052
(3/4" x 3")

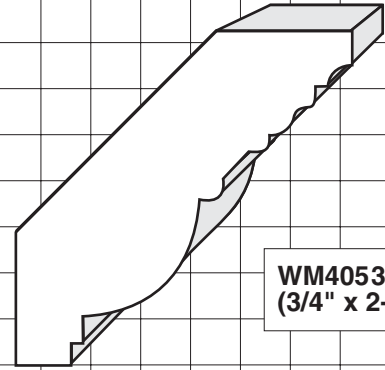

WM4053
(3/4" x 2-1/2")

CROWNS

WM4054
(3/4" x 5")

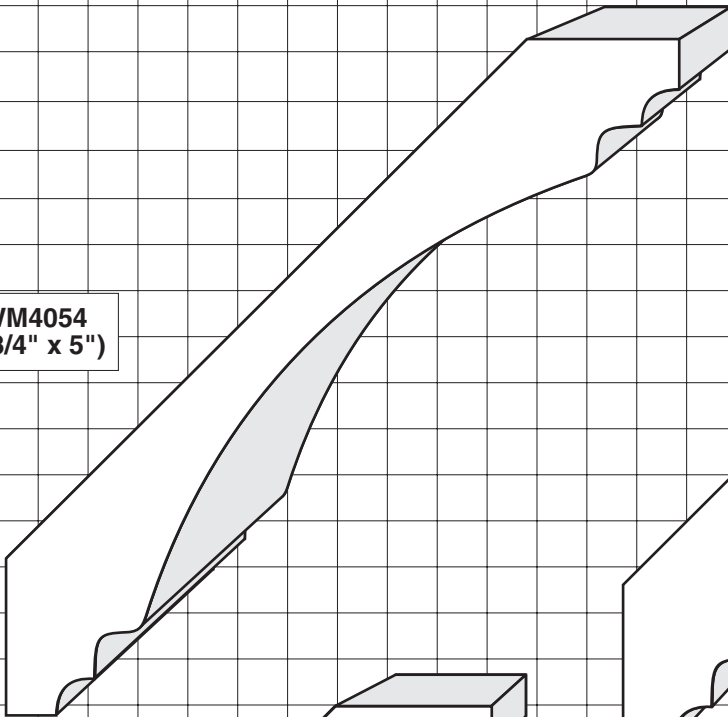

WM4055
(3/4" x 4-1/2")

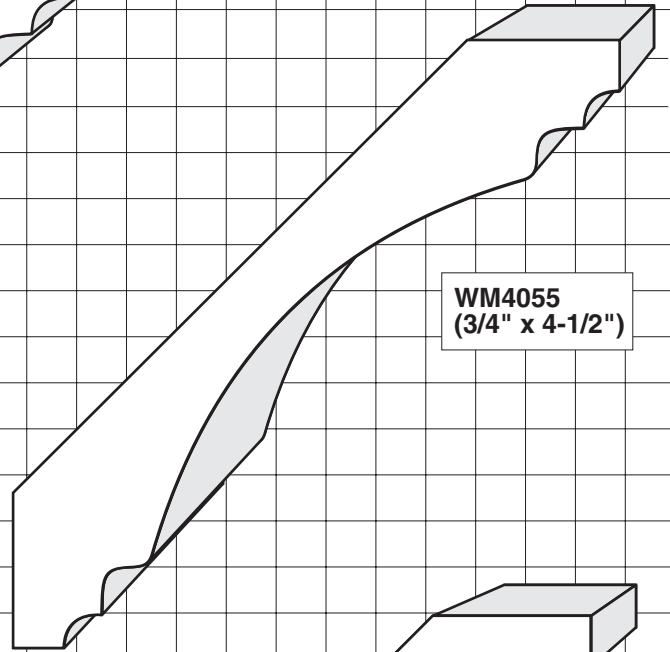

WM4056
(3/4" x 4")

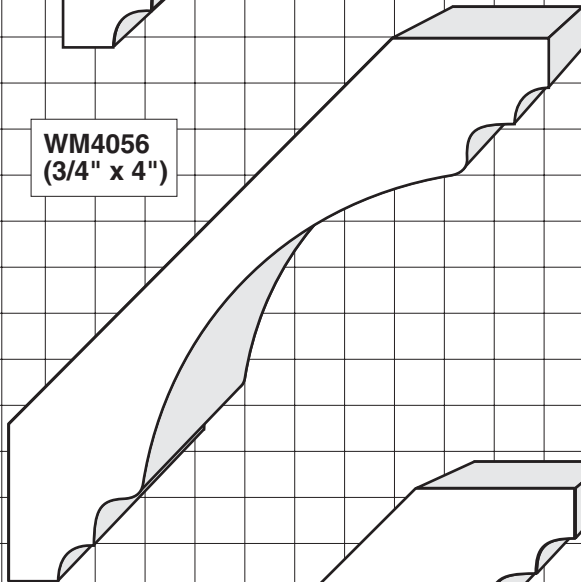

WM4057
(3/4" x 3-1/2")

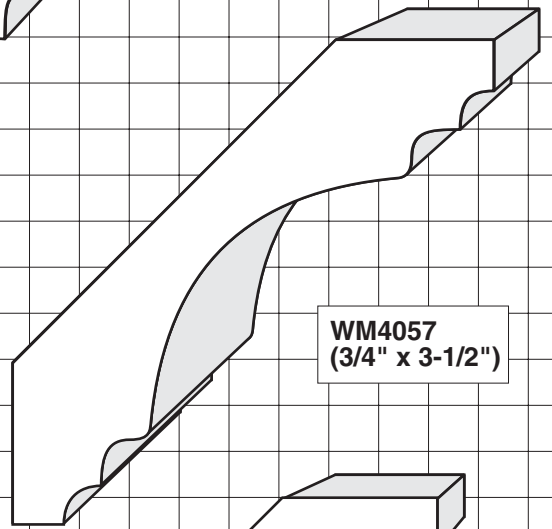

WM4058
(3/4" x 3")

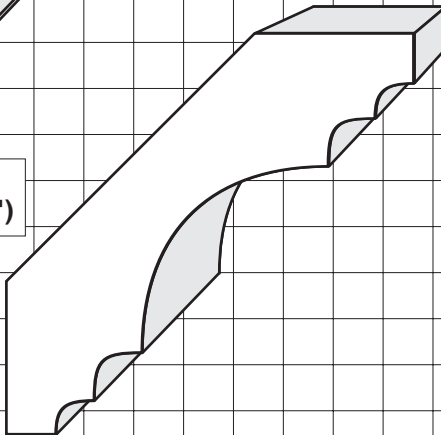

WM4059
(3/4" x 2-1/2")

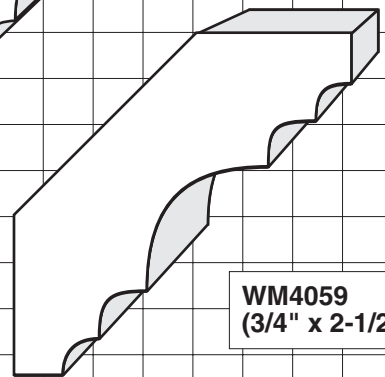

CROWNS

WM4064
(7/8" x 5-1/4")

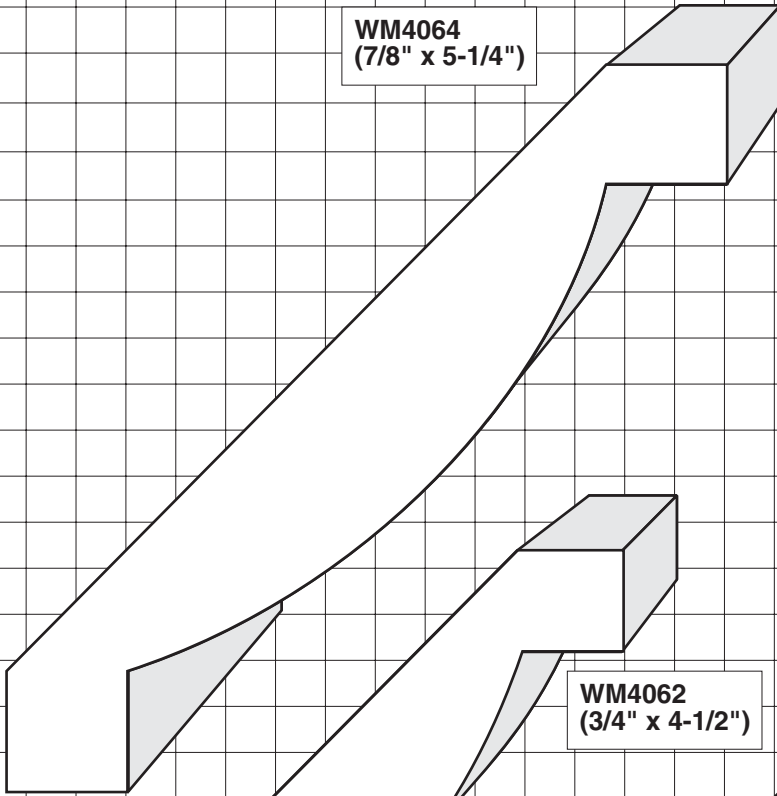

WM4063
(3/4" x 5-1/4")

WM4062
(3/4" x 4-1/2")

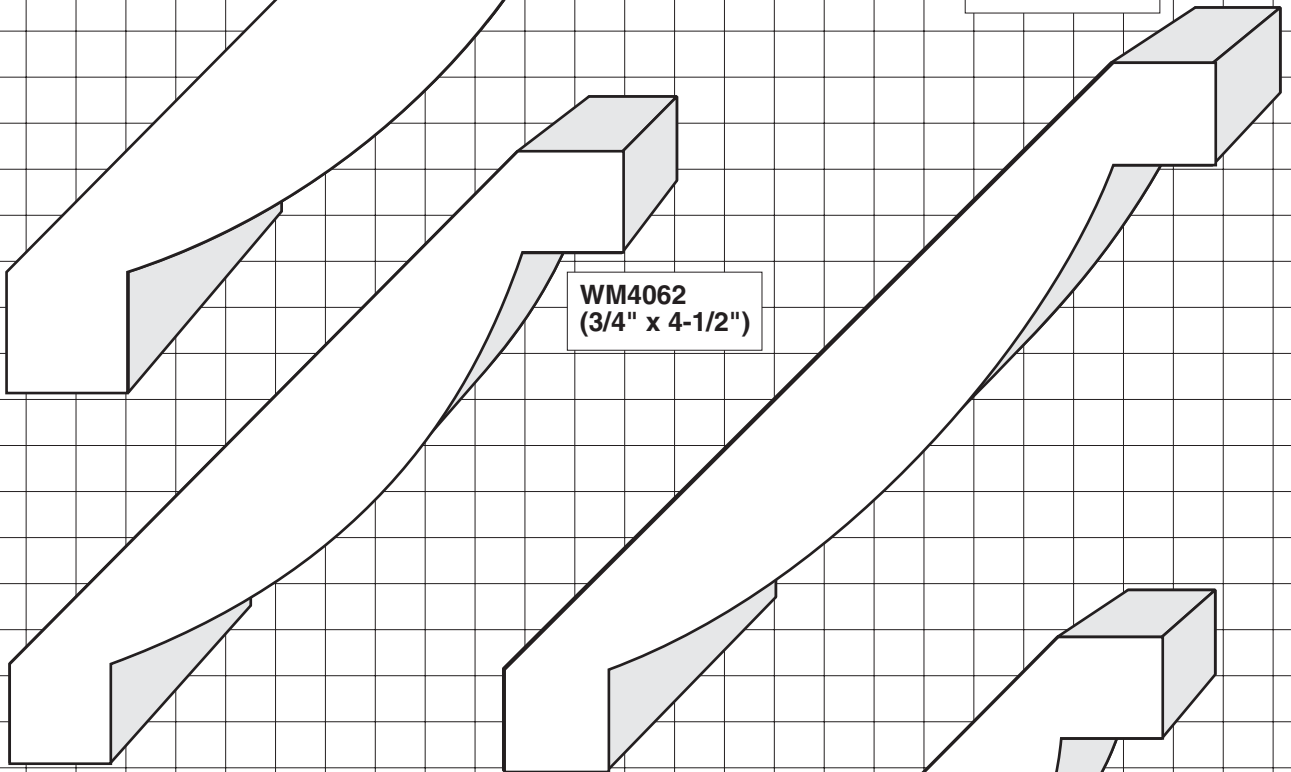

WM4060
(3/4" x 2-1/2")

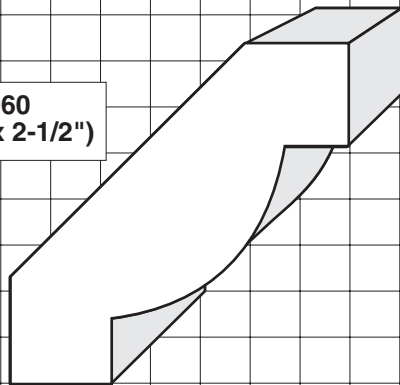

WM4061
(3/4" x 3-1/2")

